



Tabletop & Folding Displays

SYMBOLS USED



product can be recycled
(does not include graphic
application)



product comes with a carry
bag or case



product is made in the U.S.

WARRANTY KEY



lifetime warranty
(hardware)



5 year warranty
(hardware)



1 year warranty
(hardware)

the **COYOTE**
MINI popup



- approx. 20% smaller than standard Coyote tabletops
- entire display rolls up into special storage sleeve which slides into a padded carry case
- kit includes frame, channel bars, panel hangers, carry case, & 2 lights
- add an optional OCS hard case for shipping or extra secure storage



2x2 mini tabletop kit
footprint dimensions:
48" h x 53.625" w x 11.75" d



3x2 mini tabletop kit
footprint dimensions:
48" h x 74.625" w x 15.75" d

COYOTE OPTIONS

Customize your Coyote display with a variety of optional accessories.



Lumina 200 & Lumina 7 are excellent lighting solutions for your Coyote popup exhibit (see page 48)



INTERNAL SHELF KIT



- presents products or literature
- comes with 2 clear acrylic shelves to be used horizontally or at 45° angles
- max capacity per shelf= 15 lbs, max per quadrant= 45 lbs
- for use with curved frame only
- **lighting package available**



MONITOR MOUNT



- combine print and digital images to strengthen your message
- fully integrated with straight or curved Coyote systems
- one panel will be cut to fit the monitor and feet
- LCD max size= 32"
- (not recommended for plasma or CRT units)

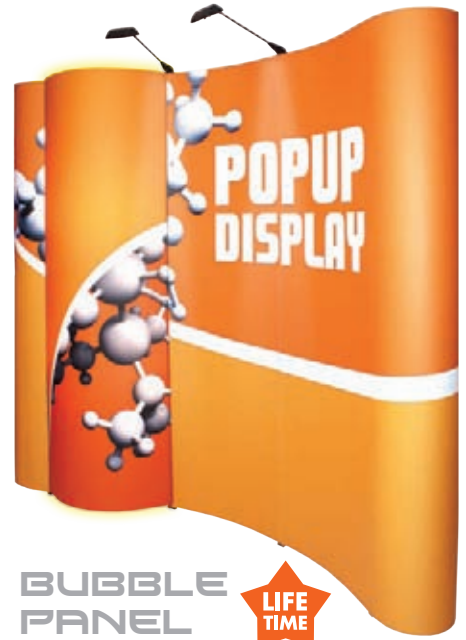

BUBBLE PANEL



- forward facing, convex panel
- panel can be fabric, opaque graphic or rear illuminated graphic (light kit sold separately)
- hardware can be stored with display in OCP

HORIZON 6

WEIGHS 22 LBS HZ-6



- main panel sizes approximately= 2' x 3'
- custom sized panel displays are available
- shown with optional detachable graphics
- available in a variety of fabric color options (page 23)



TABLETOP | STANDARD

WEIGHS 12 LBS HZ-TT-S



- 3 panels plus a header
- shown with optional detachable graphics
- available in a variety of fabric color options (page 23)

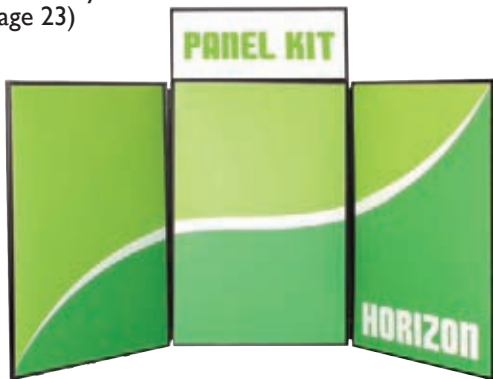

TABLETOP | DELUXE MASTER

WEIGHS 13.5 LBS HZ-TT-M



- detachable graphics available
- available in a variety of fabric color options (page 23)



HORIZON 8

WEIGHS 31 LBS HZ-8

- 8 panel kit
- complete backwall with 2 headers
- detachable graphics available
- available in a variety of fabric color options (page 23)



EFEX

- 2801 three panel kit: EFX-2801
- 2802 three panel kit w/header: EFX-2802

- lightweight, fabric covered tabletop display, 28" w x 35" h



- available in a choice of 4 basic color combinations:

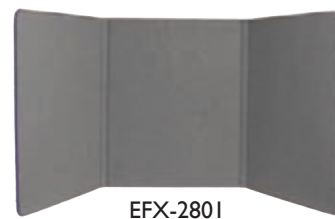
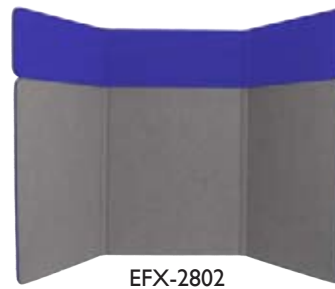
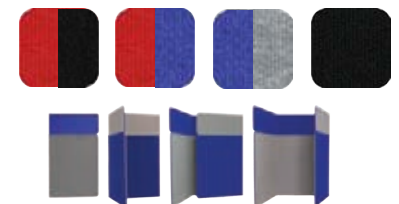

HERO

- durable premium seamless exhibit panel kits
- convenience of folding panels with elegant, seamless panel construction
- concealed hinges
- unique 2" radius curved ends lend a polished appearance
- full height units can also be used as two tabletop units
- available in a variety of fabric color options
- shown with optional detachable graphics

OCH CASE



shown with optional graphics
HERO H16

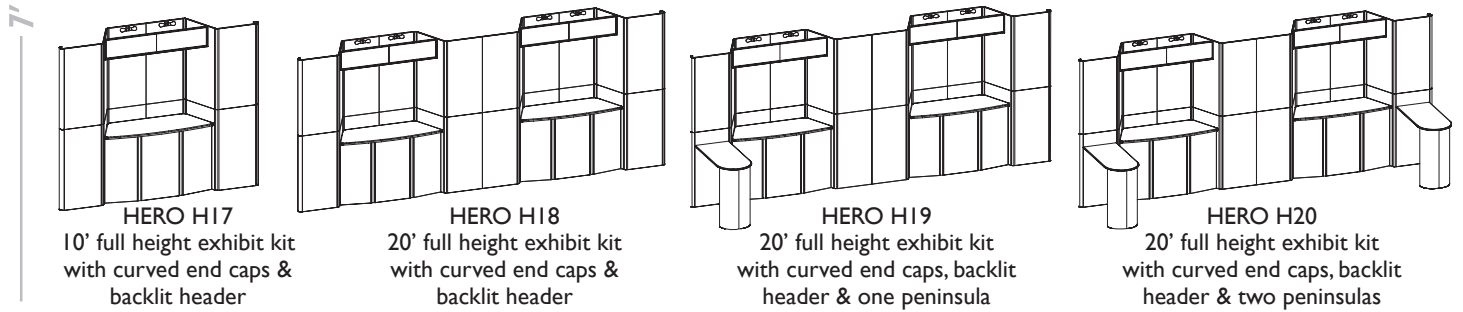
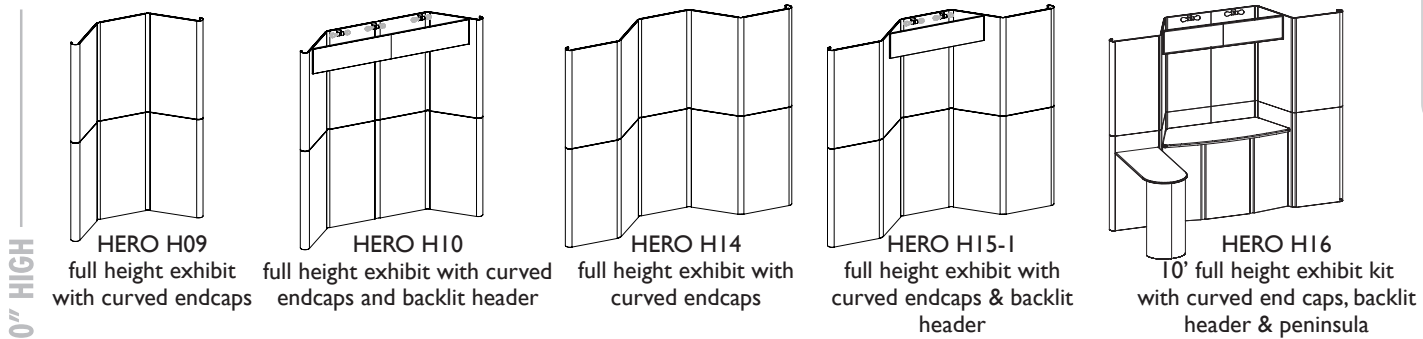
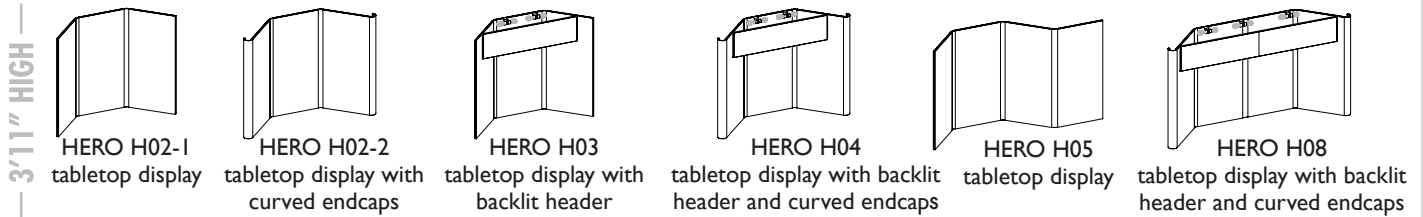

FABRIC CHOICES

All Hero & Horizon folding display panels are available with detachable graphic panels or "velcro-friendly" fabric panels of your choice. Actual fabric color may vary slightly.

Regal - smooth exhibit & display fabric



Premier - ribbed exhibit & display fabric

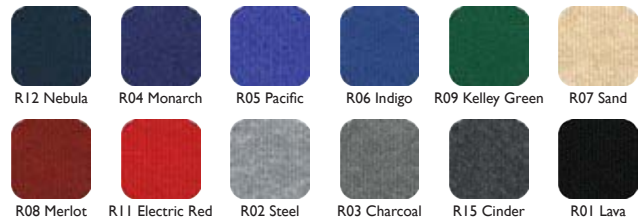

VOYAGER

24 SERIES

The Voyager has been specially developed as a briefcase style table top display and is a great choice for promotions on the go. It has a rigid, thermo formed ABS exterior and a black, Velcro compatible fabric interior.

All units are shown with Velcro detachable graphics. Header options shown with V-2 and V-3 models are also available for V-1.



FOLDING DISPLAY PANELS

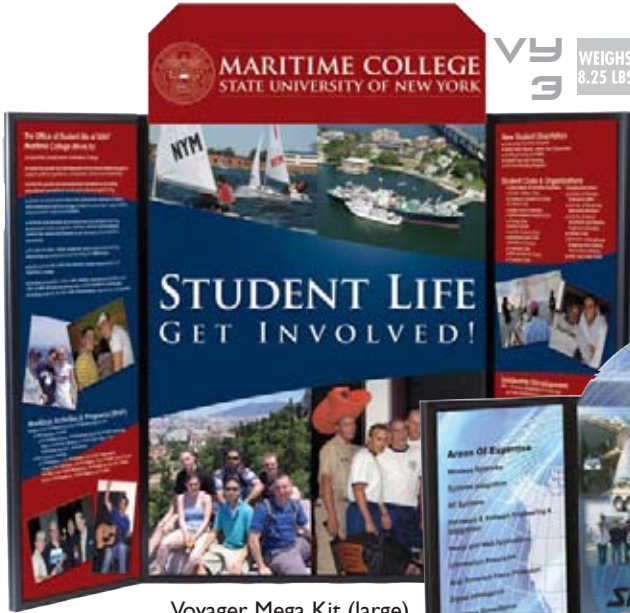

Voyager Mega Kit (large)
open dimensions: 32" h x 48" w
closed dimensions: 32" h x 24" w

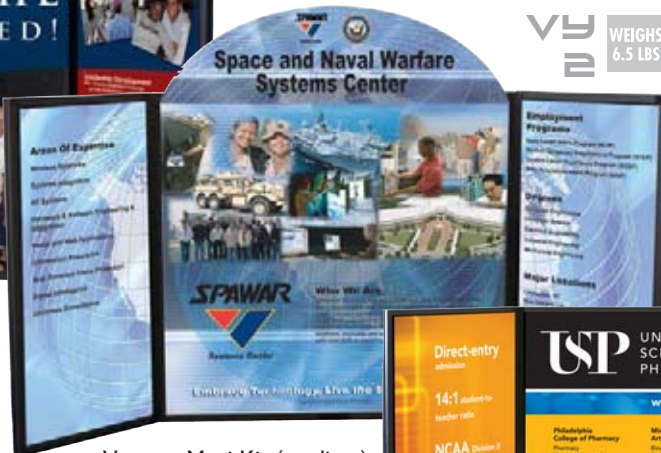

Voyager Maxi Kit (medium)
open dimensions: 24" h x 48" w
closed dimensions: 24" h x 24" w



Voyager Mini Kit (small)
open dimensions: 18" h x 48" w
closed dimensions: 18" h x 24" h



VOYAGER CARRY BAG

- Voyager Mini bag: VY-1-BG
- Voyager Maxi bag: VY-2-BG
- Voyager Mega bag: VY-3-BG
- Voyager Supreme bag: VY-4-BG
- Voyager Monster bag: VY-5-BG



CUSTOMIZE

Brand the exterior of your Voyager to match your company and/or product colors to maximize your marketing efforts. Minimum 12 units, call for details.

32 SERIES

All Voyager systems have a limited Lifetime Warranty. Internal graphics can remain on the Voyager during transport. Header options should be removed for transport and storage.



VY 5
WEIGHS 10 LBS



Voyager Monster kit (xx-large)
open dimensions: 32”h x 64”w
closed dimensions: 32”h x 32”w

Detachable graphics allow for easy changes! Extra graphics can be stored in the display case and packed away for easy storage.



Voyager Supreme kit (x-large)
open dimensions: 24”h x 64”w
closed dimensions: 24”h x 32”w

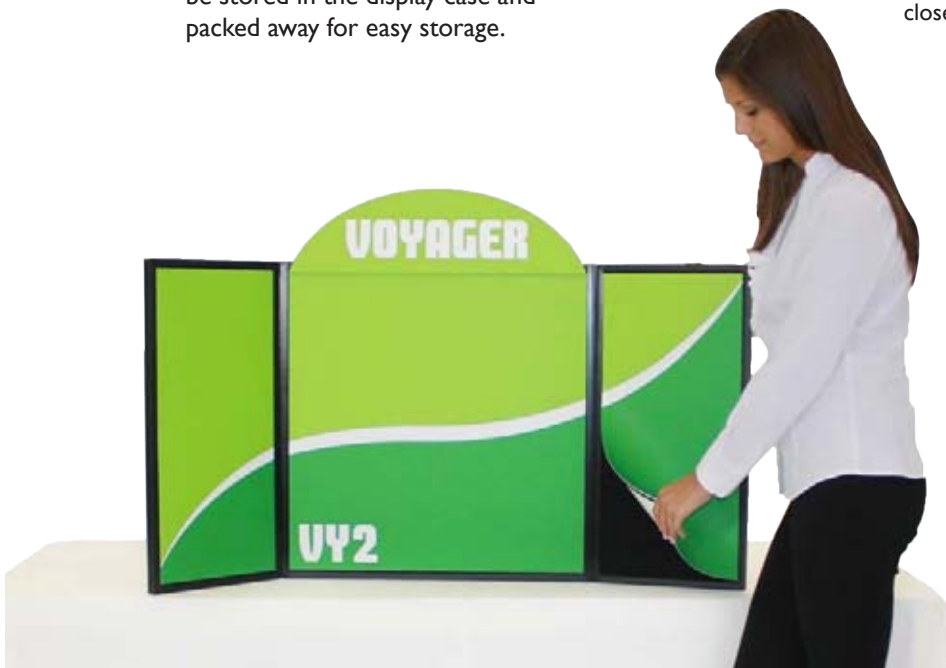

Carry your Voyager hands-free by adding a water-resistant canvas carry bag with shoulder strap. Stores header, extra graphics & literature.



LUMINA 1

silk black: LUM-1-B
chrome: LUM-1-C

- low voltage 50 watt spotlight
- "goose neck" arm
- mounts horizontally

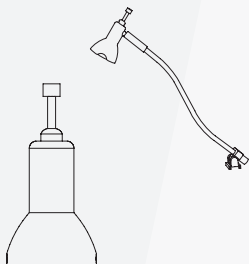

LUMINA 2

LUM-2

- low voltage 35 watt slender spotlight
- mounts to a vertical pole
- brushed stainless steel finish

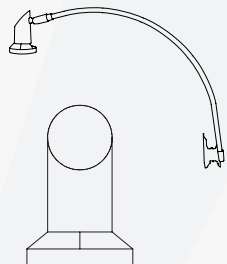

LUMINA 3

LUM-3

- low voltage 50 watt
- spotlight, chrome with a black head
- telescopic arm
- extends from 7"-22" long

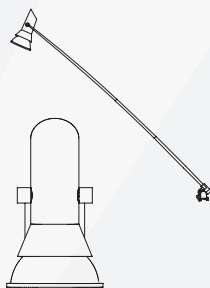

LUMINA 5

LUM-5

- low voltage 50 watt spotlight
- deluxe chrome head
- telescopic arm
- extends from 7"-22" long

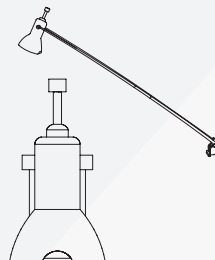

LUMINA 6

LUM-6

- low voltage, 50 watt spotlight
- stylish curved twin arms
- silk black only

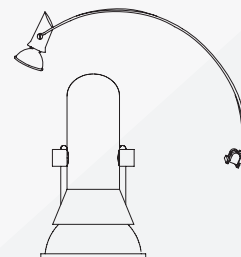

LUMINA 7

LUM-7

- incandescent 110 volt fixture
- dovetail mount
- 45 watt incandescent bulb included
- silk black only

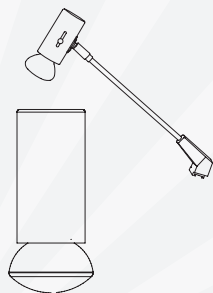

LUMINA 8

silk black: LUM-8-B
painted silver: LUM-8-C

- 12 volt spotlight with straight arm & adjustable head
- includes 110 volt UL approved transformer, 50 watt bulb & universal fittings kit
- 17" (431.8 mm) long from end to end

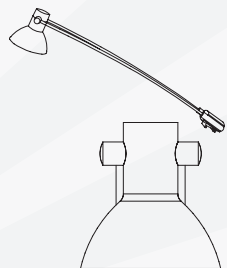

LUMINA 200

LUM-200 ORL

- 110 volt ETL approved wall washer floodlight with a straight arm & adjustable head
- light includes 200 watt halogen bulb
- 19.5" (495.3 mm) long from end to end
- silk black finish

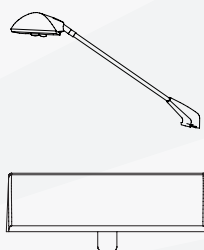

LUMINA 200 LED

LUM-LED-ORL-B

- LED version of the Lumina 200 floodlight
- 1400 Ma, 12VDC
- LED rated for 20,000 continuous hours

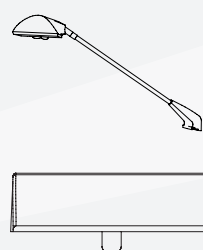

LUMINA SPARE BULB KIT

LUM-BULB
- (2) 50 watt low voltage spare bulbs in a padded, protective EVA formed case



UNIVERSAL LIGHT CLAMP KIT

UNI-LT-CLP
- comes standard with the Lumina 1, 3, 4, 5, 6, 8, 9, 10, 11, 12, 13 and allows our lights to fit a majority of banners, truss & panel kits

LED BULB OPTION

MR11: LUM-LV-LED-BLB11
- a green solution for Lumina 2
- 3 watt LED bulb

MR16: LUM-LV-LED-BLB16
- a green solution for Lumina 1, 3, 4, 5, 6, 8, 10, 11, 12, & 13
- 5 watt LED bulb



MR11

MR16



All our lighting options come with a one year warranty.