



- fully magnetic popup display system providing a graphic or fabric backwall
- available in a wide range of size configurations (see page 15)





OCP



OCP

- general purpose transit case
- blow molding makes case strong yet lightweight
- built in wheels, handle
- light storage in the lid
- secure reinforced straps help to assure case will remain closed during transport
- recommended for Coyotes & Hopups



CASE TO COUNTER CONVERSION

Roll Wrap: OCP-C2C-G



- available in fabric or graphic
- converts OCP to a counter
- polymer counter surface exposed



Stretch Wrap: OCP-SW-G



- stretch fabric pullover
- converts OCP to a counter
- polymer counter surface covered by fabric



OCP ELITE

OCP-ELITE



- heavy duty shipping and storage case
- lid can be used as a step stool while assembling displays
- access door provides storage when unit is used as a counter
- UPS approved



CASE TO COUNTER CONVERSION

Roll Wrap: ELITE-C2C-G



- available in fabric or graphic
- converts OCP Elite to a counter
- counter surface exposed



Stretch Wrap: ELITE-SW-G



- stretch fabric pullover
- converts OCP Elite to a counter
- counter surface covered by fabric

OCS AND OCL

small: OCS
large: OCL



- blow molded cases for exhibits & graphics
- reliable built-in wheels
- easy-to-grip molded handles
- secure reinforced straps help to assure case will remain closed during transport



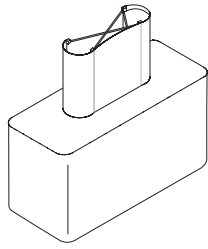

1x1 tabletop
footprint dimensions:
30.625"h x 45.5"w x 12.5"d

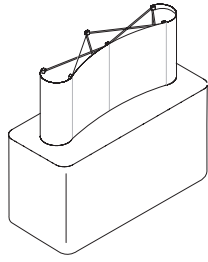

2x1 tabletop
footprint dimensions:
30.625"h x 73"w x 19.25"d

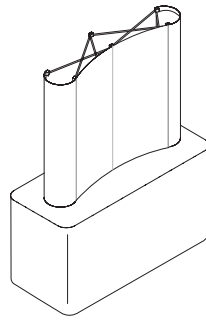

2x2 tabletop kit
footprint dimensions:
59.375"h x 73"w x 19.25"d

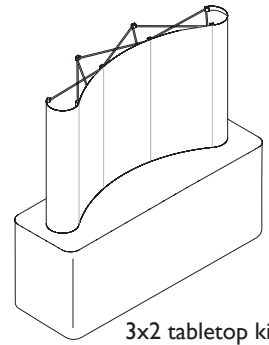

3x2 tabletop kit
footprint dimensions:
59.375"h x 97.25"w x 25"d

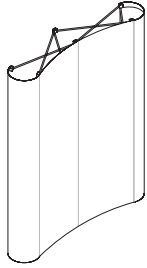

2x3 full height
slim-line display system
footprint dimensions:
87.56"h x 73"w x 19.25"d

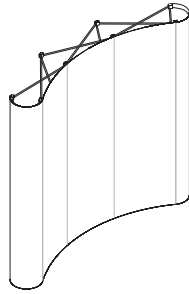

3x3 full height
standard display system
footprint dimensions:
87.56"h x 97.25"w x 25"d

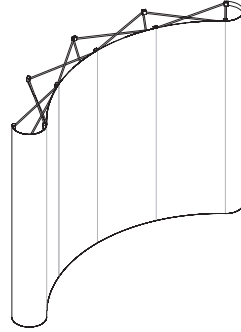

4x3 full height
standard display system
footprint dimensions:
87.56"h x 118"w x 36.5"d

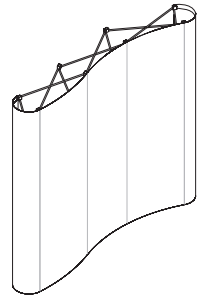

3x3 serpentine
full height display system
footprint dimensions:
87.56"h x 89.5"w x 19.5"d

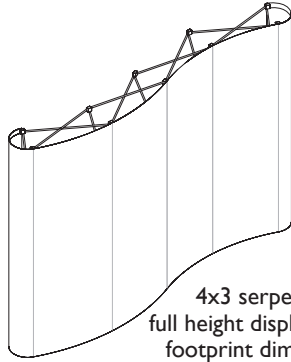

4x3 serpentine
full height display system
footprint dimensions:
87.56"h x 129.5"w x 19.5"d

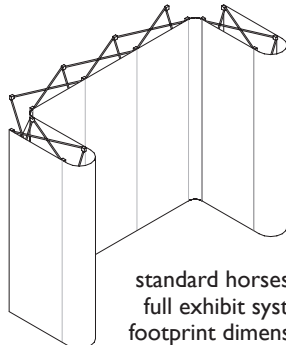

standard horseshoe
full exhibit system
footprint dimensions:
87.56"h x 113"w x 54"d

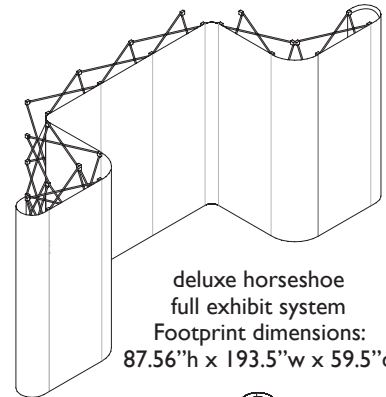

deluxe horseshoe
full exhibit system
Footprint dimensions:
87.56"h x 193.5"w x 59.5"d

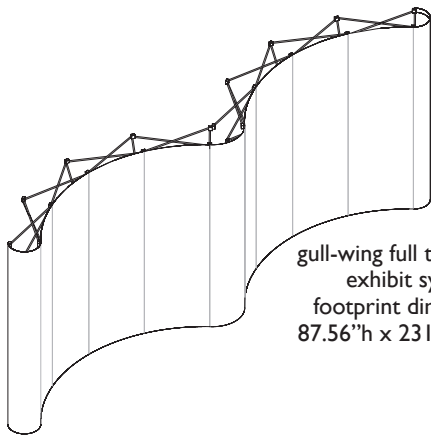

gull-wing full trade show
exhibit system
footprint dimensions:
87.56"h x 231"w x 41"d

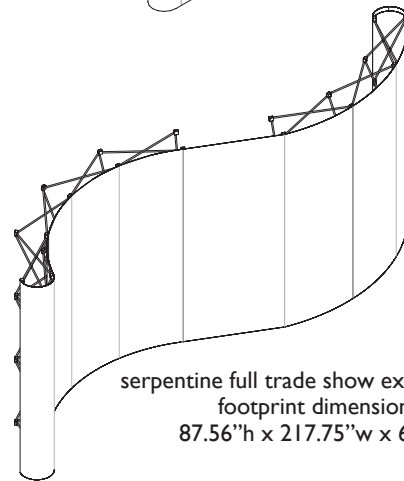

serpentine full trade show exhibit system
footprint dimensions:
87.56"h x 217.75"w x 60.5"d

FABRIC CHOICES

All Coyote popup display systems are available with printed graphic murals or "velcro-friendly" fabric panels of your choice. Actual fabric color may vary slightly.

Regal - smooth exhibit & display fabric



Premier - ribbed exhibit & display fabric

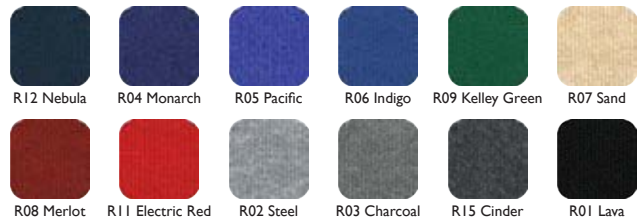

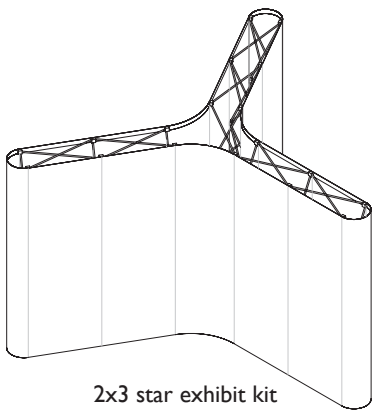

2x3 star exhibit kit

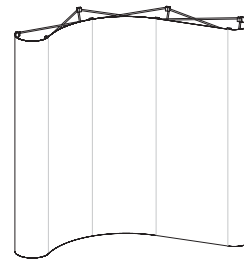
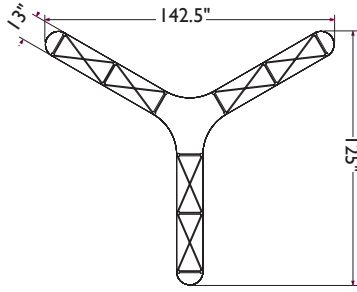

3x3 "L" exhibit kit

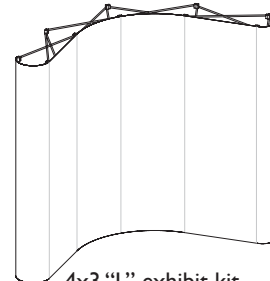
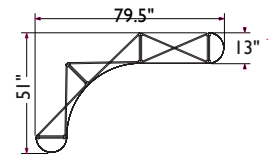

4x3 "L" exhibit kit

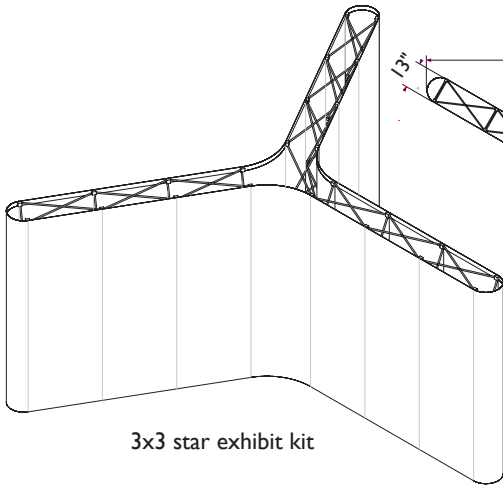
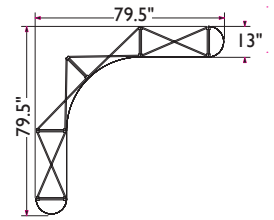

3x3 star exhibit kit

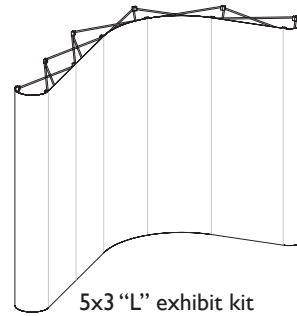
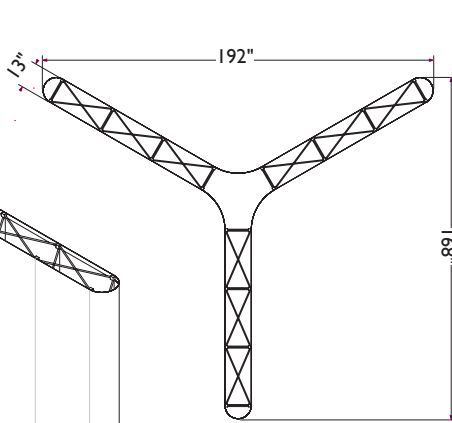

5x3 "L" exhibit kit

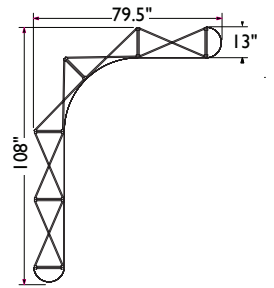

COYOTE ACCENT KIT
COY-ACCT-K



- a fresh new look for your Coyote popup
- update your current display with 2 modern wing shapes and 4 extrusions



COYOTE TOWER
COY-3-G-TOW



- an unexpected addition to any display; large or small, exhibit or P.O.P
- back-lit panels illuminate your graphics
- coordinates with the look and style of your Coyote popup display



the **COYOTE**
MINI popup



- approx. 20% smaller than standard Coyote tabletops
- entire display rolls up into special storage sleeve which slides into a padded carry case
- kit includes frame, channel bars, panel hangers, carry case, & 2 lights
- add an optional OCS hard case for shipping or extra secure storage



2x2 mini tabletop kit
footprint dimensions:
48" h x 53.625" w x 11.75" d



3x2 mini tabletop kit
footprint dimensions:
48" h x 74.625" w x 15.75" d

COYOTE OPTIONS

Customize your Coyote display with a variety of optional accessories.



Lumina 200 & Lumina 7 are excellent lighting solutions for your Coyote popup exhibit (see page 48)



INTERNAL SHELF KIT



- presents products or literature
- comes with 2 clear acrylic shelves to be used horizontally or at 45° angles
- max capacity per shelf= 15 lbs, max per quadrant= 45 lbs
- for use with curved frame only
- **lighting package available**



MONITOR MOUNT



- combine print and digital images to strengthen your message
- fully integrated with straight or curved Coyote systems
- one panel will be cut to fit the monitor and feet
- LCD max size= 32"
- (not recommended for plasma or CRT units)

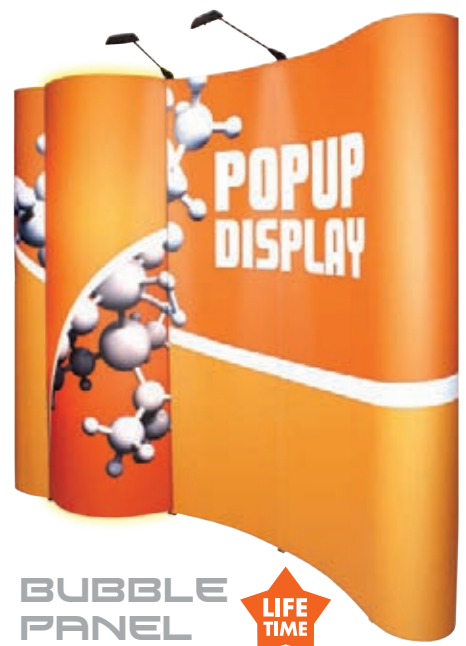

BUBBLE PANEL



- forward facing, convex panel
- panel can be fabric, opaque graphic or rear illuminated graphic (light kit sold separately)
- hardware can be stored with display in OCP